



Mix-N-Go Concrete Mixers

Multiquip General Construction Equipment Division



Model MC-3SEA

Model MC-3PEA

Welcome to the future of portable concrete mixers.

The new Mix-N-Go combines a host of performance-enhancing features with ease of transportation to, from and around the job site. It can mix up to three cubic feet of material ($\frac{1}{2}$ bag), making the mixer the tool of choice for homeowners and small contractors.

With a stronger frame and sturdy steel or polyethylene drum, the Mix-N-Go is ideal for small footings and bases, binding block and concrete patching. It is available with a gasoline engine or electric motor for operator convenience and for increased versatility. It can also be used as a wheelbarrow to transport concrete, debris and other material around the job site.

When the job is complete, the compact Mix-N-Go fits neatly into the trunk of a car.

- New replaceable blades bolted to the drum.
- Choice of steel or polyethylene drums.
- Engine options — Gasoline or 1.0 HP, 115 single-phase UL- and CSA-approved electric motor.
- Job site convenience — can use standard household power.
- Mixer stand allows drum to rotate 360 degrees.
- New on/off switch protection — water-resistant and dust proof.
- Improved drum capacity — a maximum 4.5 cubic feet.
- Pneumatic tires



Mix-N-Go Concrete Mixers

Specifications

Model	Drum Construction	Max. Drum Capacity cu.ft. (m ³)	Max. Mixing Capacity	Engine	Height in. (mm)	Width in. (mm)	Length in. (mm)	Stand Weight lbs. (kg)	Dry Weight lbs. (kg)
MC3SEA	Steel	4.5 (0.13)	½ bag (3.0 cu. ft.)	1.0 HP, 115V, 1Ø Electric Motor	34 (863.6)	23 ⁵ / ₈ (584.2)	48½ (1219.2)	35 (15.9)	138 (62.6)
MC3PEA	Polyethylene	4.5 (0.13)	½ bag (3.0 cu. ft.)	1.0 HP, 115V, 1Ø Electric Motor	34 (863.6)	23 ⁵ / ₈ (584.2)	48½ (1219.2)	35 (15.9)	138 (62.6)
MC3SBA	Steel	4.5 (0.13)	½ bag (3.0 cu. ft.)	Briggs & Stratton 3.5 HP	34 (863.6)	23 ⁵ / ₈ (584.2)	48½ (1219.2)	35 (15.9)	132 (59.9)
MC3PBA	Polyethylene	4.5 (0.13)	½ bag (3.0 cu. ft.)	Briggs & Stratton 3.5 HP	34 (863.6)	23 ⁵ / ₈ (584.2)	48½ (1219.2)	35 (15.9)	132 (59.9)



Bolt-in replaceable mixing blades
Stronger, thicker drum (available in steel or poly)

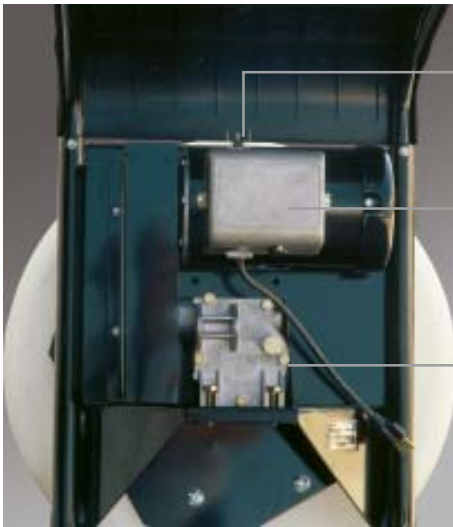

Water-resistant, dust-proof on/off switch
Stronger 1.0 HP brushless motor, UL and CSA approved
Improved gearbox for reduced friction operation

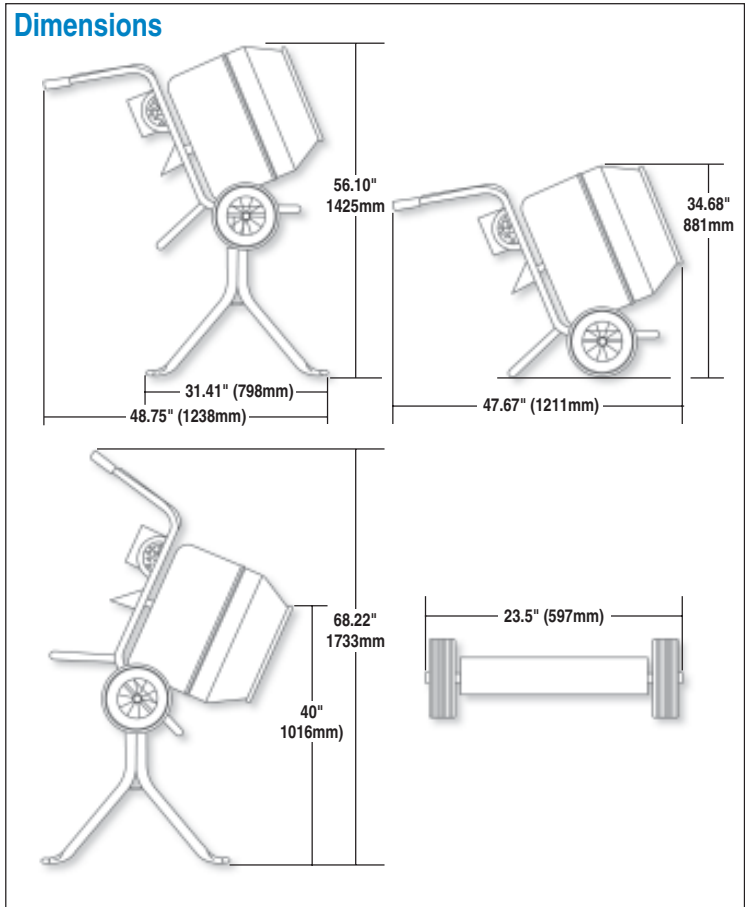

Note: All features and specifications are subject to change without notice and will vary by model and engine.

Your Multiquip dealer is:



MULTIQUIP INC.
POST OFFICE BOX 6254
CARSON, CA 90749
310-537-3700 • 800-421-1244
FAX: 310-537-3927
E-MAIL: mq@multiquip.com
www.multiquip.com